



TESS102 DATASHEET

INTERNAL TRAPEZOIDAL TENSION SYSTEM

Bespoke shapes to meet your requirements.
Any angle, any direction, anywhere.

Modern glazing design is anything but square. For special shapes including domes and tapered windows, the TESS 102 provides an adaptable solution. Relieving rollers allow the blind to follow the direction of curves whilst ultra-thin cables maintain fabric tension. Unlimited colour finishes and a wide range of fabrics make it suitable for any project. Our single barrel mechanism keeps the fabric constantly under tension and produces a smooth, quiet travel.

- Single barrel tension system
- Any angle, any direction
- Trapezoidal or uneven shapes
- Domes, angles and curves
- Reliable and robust

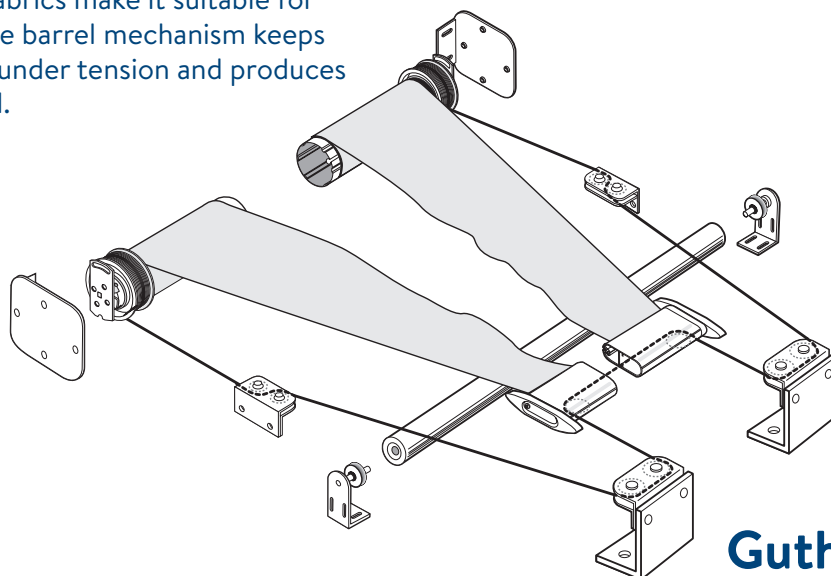

Guthrie Douglas

Guthrie Douglas Shading Tension Systems are distributed in Australia and New Zealand by Horiso®

Horiso®
T: +61 2 8755 4500 E: info@horiso.com.au
horiso.com.au

horiso®

TOP FIX

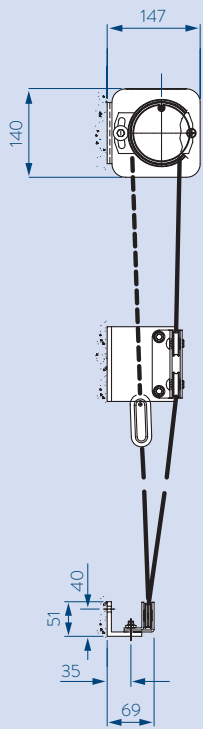

BACK FIX

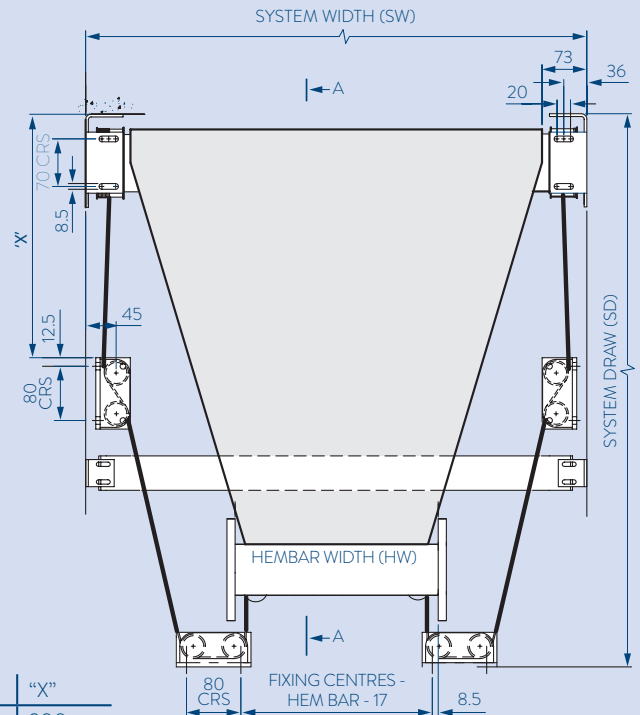
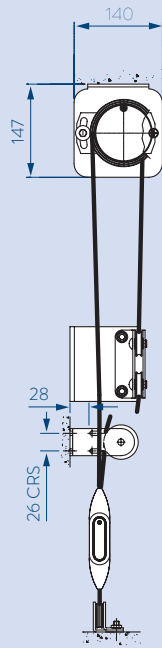

SD	"X"
1000 - 2000mm	200mm
2100 - 3000mm	250mm
3100 - 4000mm	300mm
4100 - 5000mm	350mm
5100 - 6500mm	400mm

KEYFACTS

Typical use	Flat, curved or sloped glazing
Shape	Trapezoidal
Running direction	Any
Guides	None
Width	870 mm - 4000 mm
Draw	≤6500 mm
Fabric area	≤16 m ²
Brackets	Aluminium
Relieving rollers	Aluminium
Finish	RAL Powder coat
Installation options	Top, back

TECHNICALINFO

Fabric tension	>100 N
Weight exc. fabric	~7.5 kg + 4.2 kg/m width
Fixing load	≤36 kg per bracket
Operating temp.	0 to 55 °C
Motor	15 Nm, 17 rpm
Electrical	230 V, 50 Hz, 140 W, 0.65A 120 V, 60 Hz, 130 W, 1.1A
Max run time	4 min
Fabric speed	~5 m/min
Controls	Radio, Wired

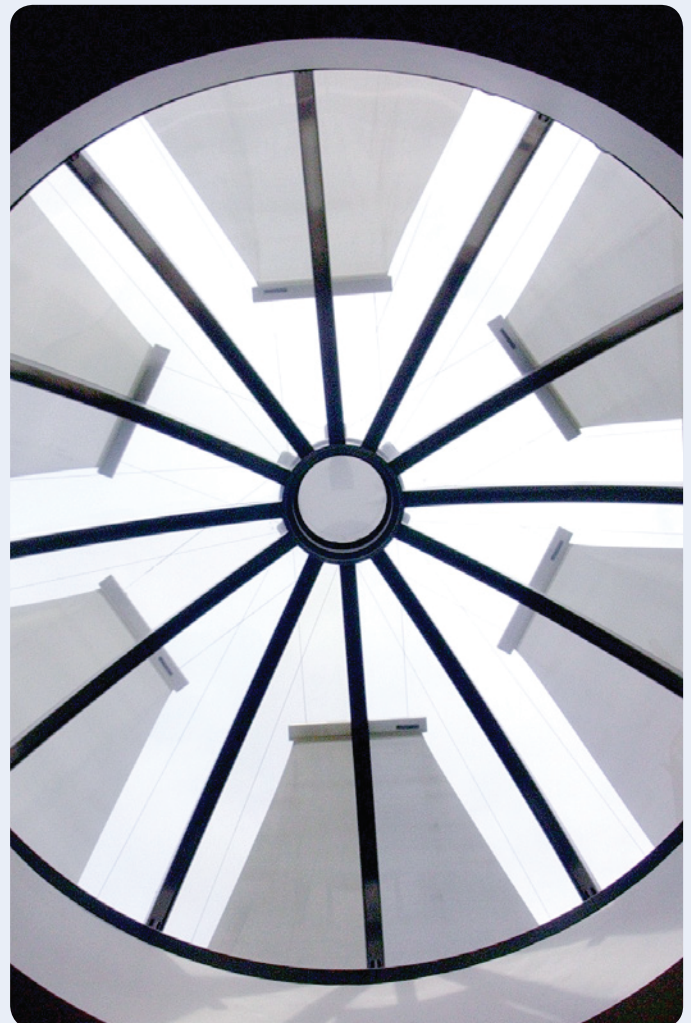

Horiso®

T: +61 2 8755 4500 E: info@horiso.com.au
horiso.com.au

horiso®